

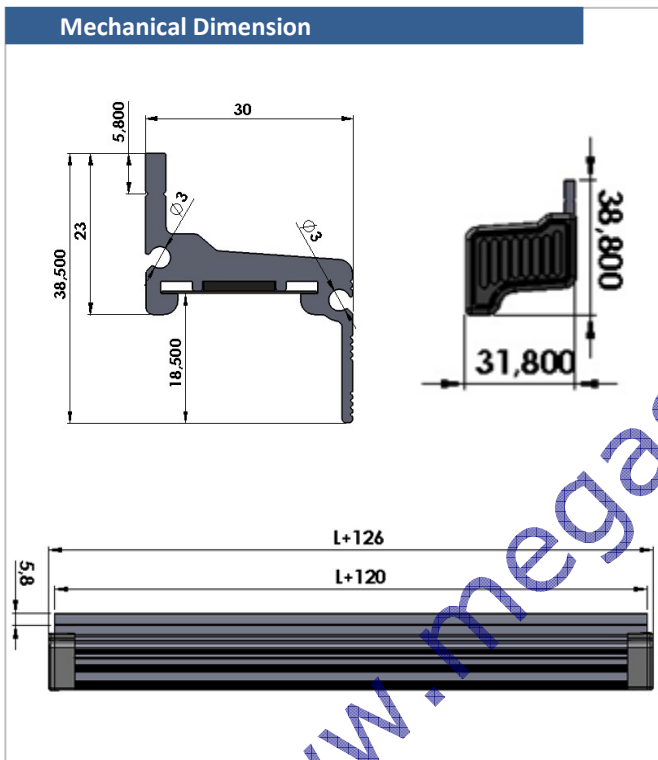

- Tape in "L" Aluminum Profile
- Contactless and Wear Free System
- Very Easy Mounting
- High Accuracy
- Protection Class IP67

In the system magnetic tape integrated in the type profile. The most important specialty of this system is easy assembly. It can be used with MLS110 and MLS 210 reader sensors.



Technical Specifications

Life	Infinite (Contactless)
Body Material	Aluminum (L) Type Profile
Gap Between Tape and Sensor	1,5 mm (Maximum 2,5 mm)
Magnetic Tape Type	B5 (Optional B2)
Operating Temperature Range	-25 to +85°
Protection Class	IP67

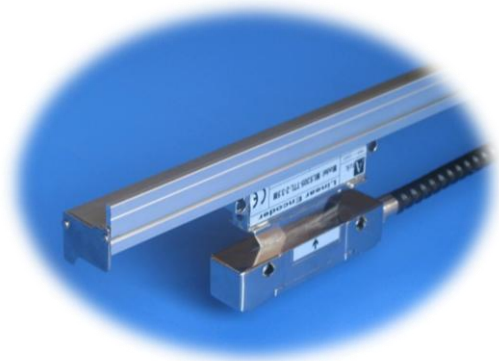

Order Specifications

Model

P	S	1	-	X	-	X	X	X	mm
---	---	---	---	---	---	---	---	---	----

Measuring Length
Optional, User Defined
Example:
300 : 300mm

N/S Pole Length
2 : 2 mm
5 : 5 mm